

# Sana

JUICER® BY 

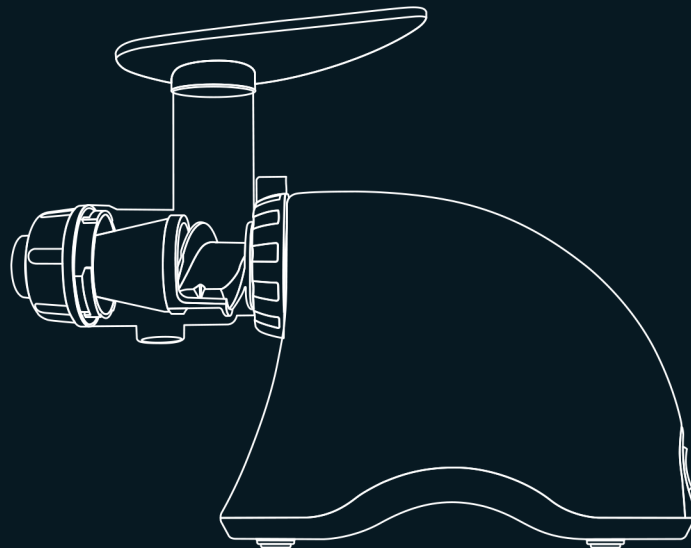

INSTRUCTION MANUAL FOR THE MASTICATING JUICER

EUJ-707

# Important Safeguards

1. Read all instructions.
2. To protect against risk of electrical shock, do not put the main body (motor) in water or any other liquid.
3. Close supervision is necessary when any appliance is used by or near children.
4. Unplug from outlet when not in use, before assembling or taking off parts and before cleaning.
5. Avoid contact with moving parts.
6. Do not operate appliance with a damaged cord or plug or after the appliance malfunctions, or is dropped or damaged in any manner. Return appliance to the nearest authorized service facility for examination, repair or electrical or mechanical adjustment.
7. The use of attachments not recommended or sold by the manufacturer may cause fire, electric shock or injury.
8. Do not let cord hang over edge of table or counter.
9. Always make sure juicer locking clip is locked while juicer is in operation.
10. Be sure to turn switch to OFF position after each use of your juicer. Make sure the motor stops completely before disassembling.
11. Do not put your fingers or other objects into the juicer while it is in operation. If food becomes lodged in the opening, use food plunger or another piece of fruit or vegetable to push it down. When this method is not possible, turn the motor off and disassemble juicer to remove the remaining food.
12. Read all the instructions and operating procedures before plugging in and using appliance.
13. Do not unplug from electrical outlet by pulling on the cord. To unplug, grasp the plug, not the cord, and pull.
14. Turn off all controls before unplugging from or plugging into an electrical outlet.

## SANA Juicer by Omega(EUJ-707)

This heavy-duty juicer features a patented, stone mill-like auger, made of hygienic U.S. FDA-approved Ultem.

The Sana Juicer by Omega (EUJ-707) working at low speed of 63-75 RPMs ensures full taste and the highest nutritional value.

The Sana Juicer by Omega (EUJ-707) is easy to assemble and disassemble for quick cleaning.

The Sana Juicer by Omega (EUJ-707) assures you many years of trouble-free, dependable service.

10-year warranty on the motor and 5-year warranty on the other parts.

## Multi-Purpose Juicer/Food Processor

### 1. Fruit Juice Extractor

The Sana juicer efficiently juices soft and hard fruits, even citrus fruits, one of the hardest fruits to juice.

### 2. Vegetable Juice Extractor

The Sana juicer efficiently juices all kinds of vegetables, including celery, carrots, peppers, radishes, and cabbage without destroying the natural flavor and nutrition. Fresh taste and full nutrition is guaranteed with this unique extraction process.

### 3. Grass Juice Extractor

Wheat grasses, aloe leaves and pine tree leaves are just some of the other natural products you can juice with the Sana juicer. Enjoy the best that nature offers in raw foods of all kinds. Juice them for full nutritional benefits.

### 4. Processing /Chopper Functions

The Sana juicer also chops and processes, garlic, scallions, red pepper, ginger, radish and many other foods, including herbs and seasonings, providing natural flavor and nutrition. Soft foods for babies and geriatric patients are quick and easy to prepare with the processing strainer.

### 5. Pasta Maker

Make fresh noodles in just minutes with the pasta nozzles. See page 14 for more information.

### 6. Homogenizer

Make fresh frozen desserts, natural baby food, and nut butters.

### 7. Grinder

Grind coffee beans and flour.

Locking Clip

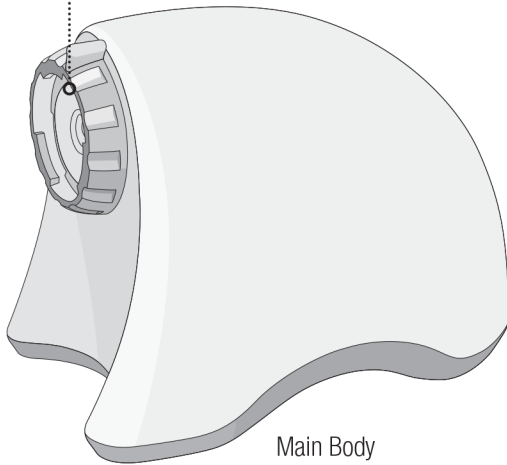

Main Body

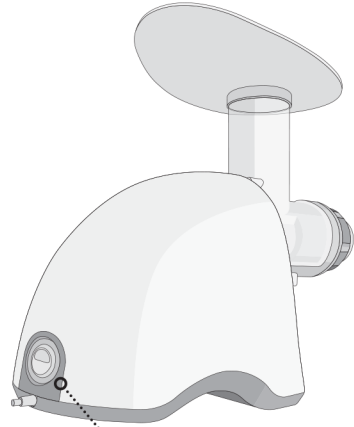

ON-OFF  
Switch

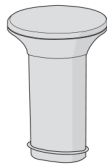
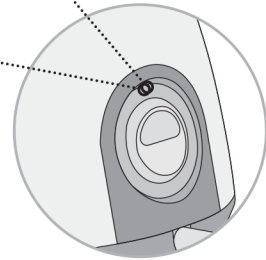

Food pusher



Container Strainer

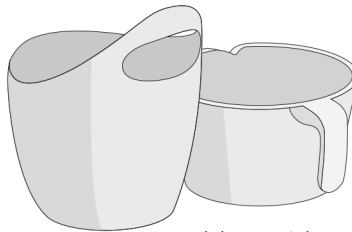

Pulp container

Juice container



Cleaning brush

**Parts for juicing**

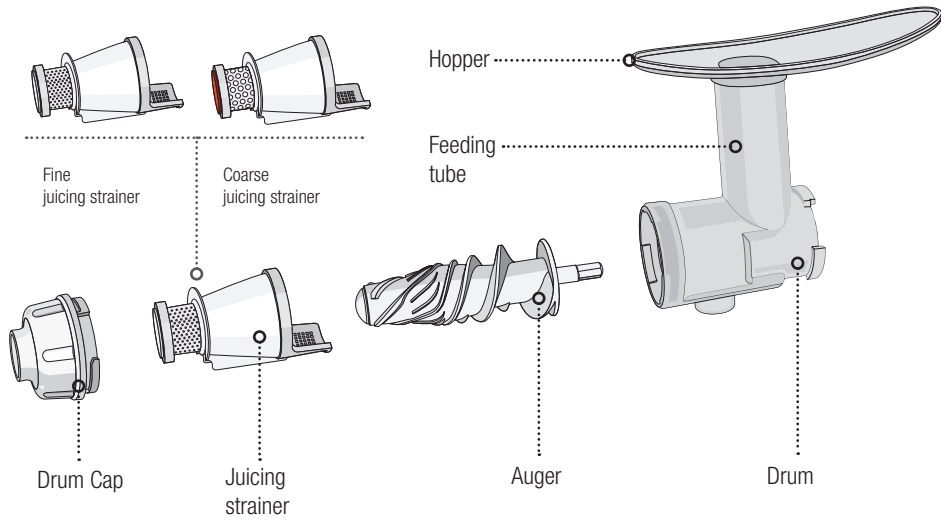

**Parts for Processing**

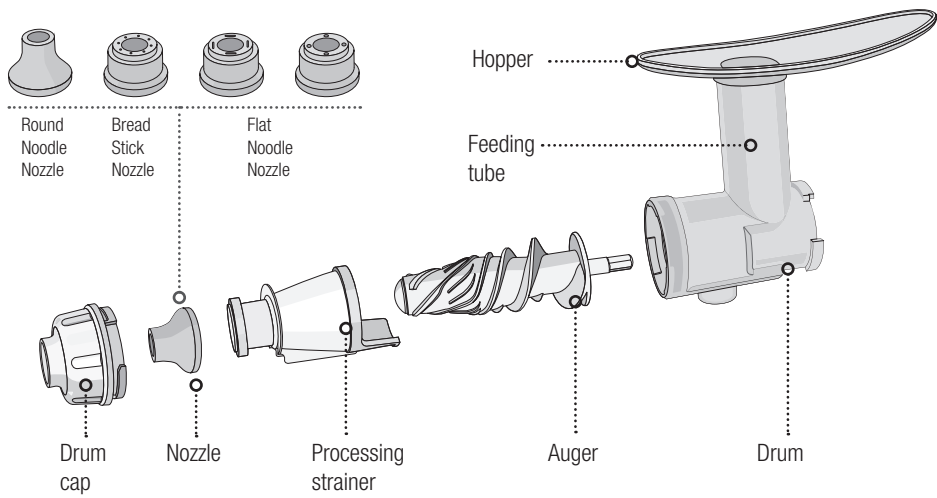



Juice fruits and vegetables  
Juice grasses  
Mince herbs & seasonings  
Make noodles and bread sticks  
Make baby food and sorbets

### Specifications

Model Name	SANA Juicer by Omega EUJ-707
Dimensions	Length: 420 mm Width: 187 mm Height: 320 mm
Voltage	230V/50Hz (150W power)
Motor	Single-phase induction
Auger RPM	63-75
Fuse	250V 5A 50T
Certified	CE

### ***Parts and Accessories Included with Your Juicer***

1 User Manual	1 Processing Strainer
2 Container	1 Food Pusher
2 Round Noodle Nozzle	1 Hopper + Drum
1 Bread Noodle Nozzle	1 Cleaning Brush
1 Flat Noodle Nozzle	1 Drum Cap
1 Auger	1 Container Strainer
2 Juicing Strainer	

***Total of 15 parts including this manual***



- 1. Thoroughly wash unpeeled fruit and vegetables before juicing.*
- 2. Cut fruit or vegetables into small pieces (about 2 inches) so juice may be extracted more thoroughly.*
- 3. Turn on the machine. Let it run without interruption until all the juice has been extracted.*
- 4. If the juicer starts to vibrate slightly during operation, turn off the machine. Empty the drum set. Re-assemble and resume normal operation.*
- 5. After placing the last pieces of fruits or vegetables into the hopper, keep the machine running for a few seconds to ensure the machine has extracted the last drops of juice.*
- 6. Turn off machine.*
- 7. Clean drum set after each use.*
- 8. Do NOT run the machine for more than 30 minutes at a time.*

## ***Cleaning Instructions***

Wash the auger and parts in warm, soapy water in your kitchen sink and rinse well.

Do not place parts or accessories in your dishwasher.

Do not immerse unit in water. Clean with a damp cloth.

# Making Juice

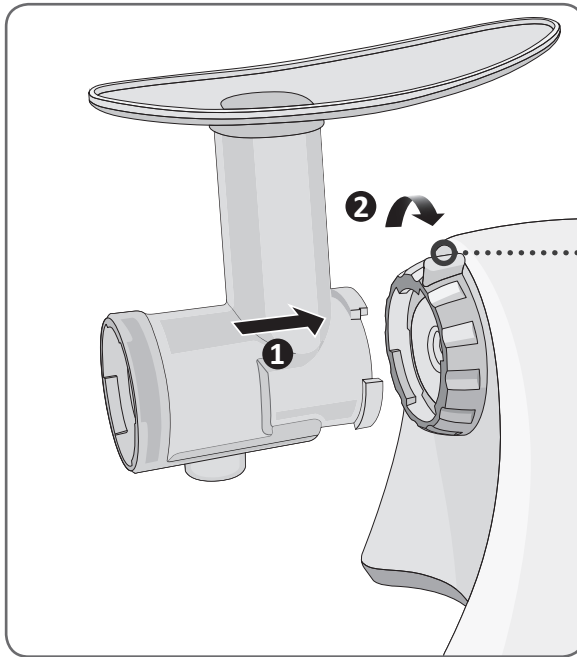

## Assembly 1

Connect drum with main body by turning locking clip clockwise (about 60°).  
Place hopper onto feeding tube.

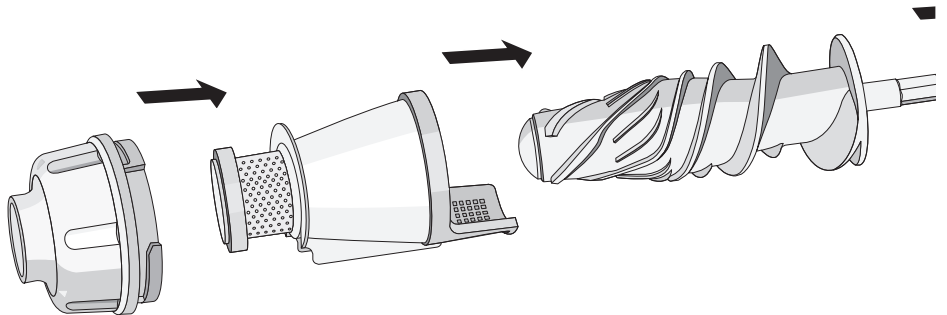
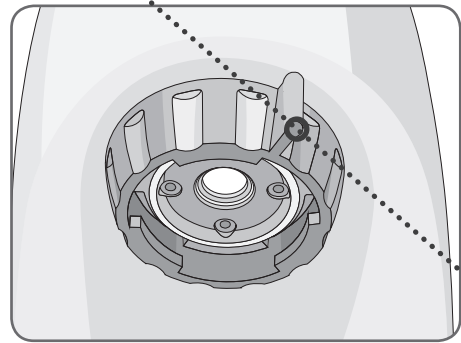



## ***Assembly 2***

### **1) Function for juicing vegetable**

Place the auger into the drum.  
Insert the fine juicing strainer into the drum.

### **2) Function for juicing fruit**

Place the auger into the drum.  
insert the coarse juicing strainer into the drum.

Place the drum cap onto the drum end and turn it counter clockwise until it clicks firmly into place.  
Attach adjustable pressure cap to the drum cap end.

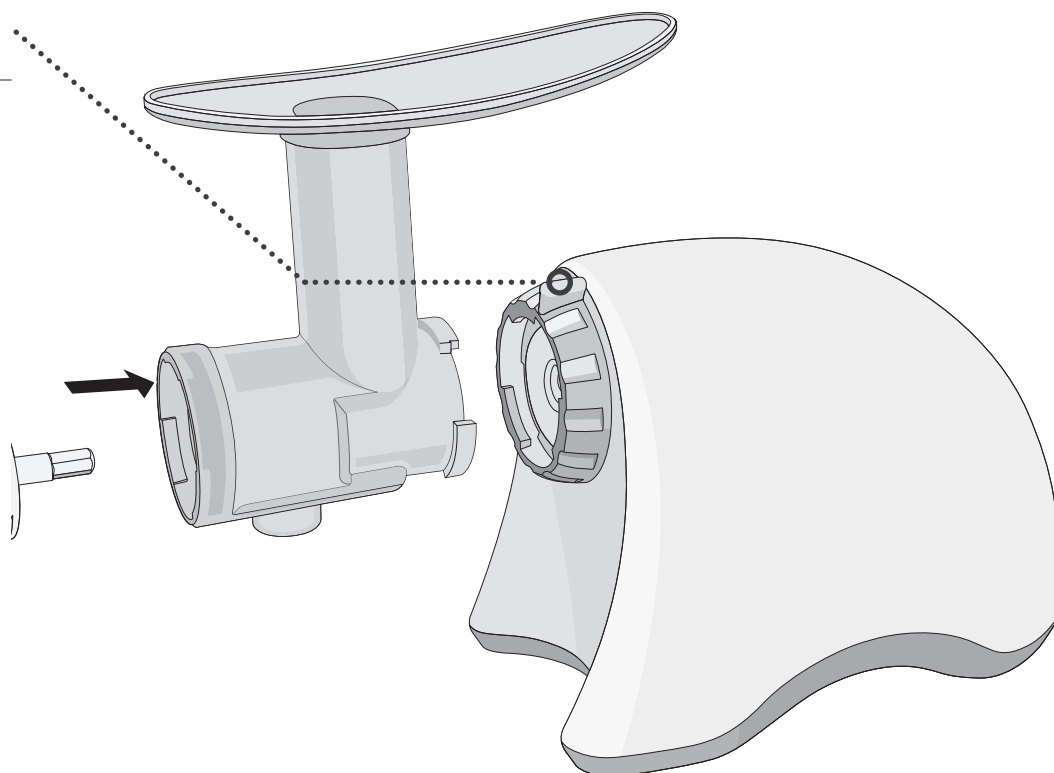

# Assembly Instructions

## Food Processor Function

For processing function,

Place the auger into the drum.

Insert the processing strainer into the drum.

Place the drum cap onto the drum end and turn it counter-clock-wise until it clicks firmly into place.

If interested in making pasta, u-dong or noodles, please refer to the "Making Pasta" section.

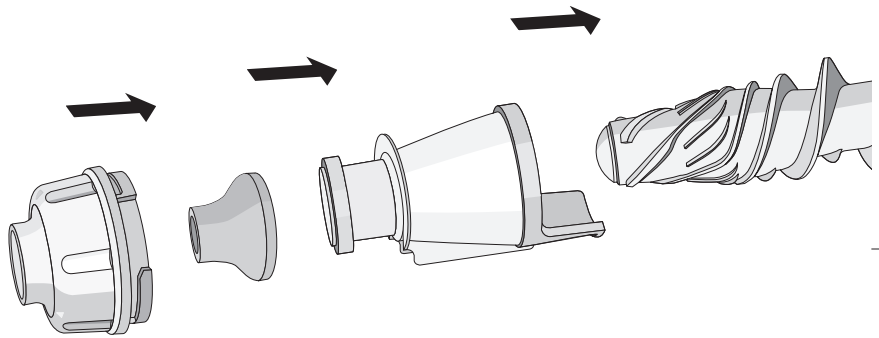

## Assembly 3

When juicing, place juice bowl and pulp bowl under drum set. When processing, you don't need the juice bowl. Plug power cord into wall outlet.

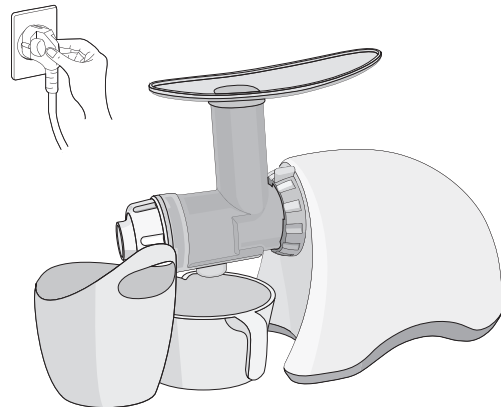

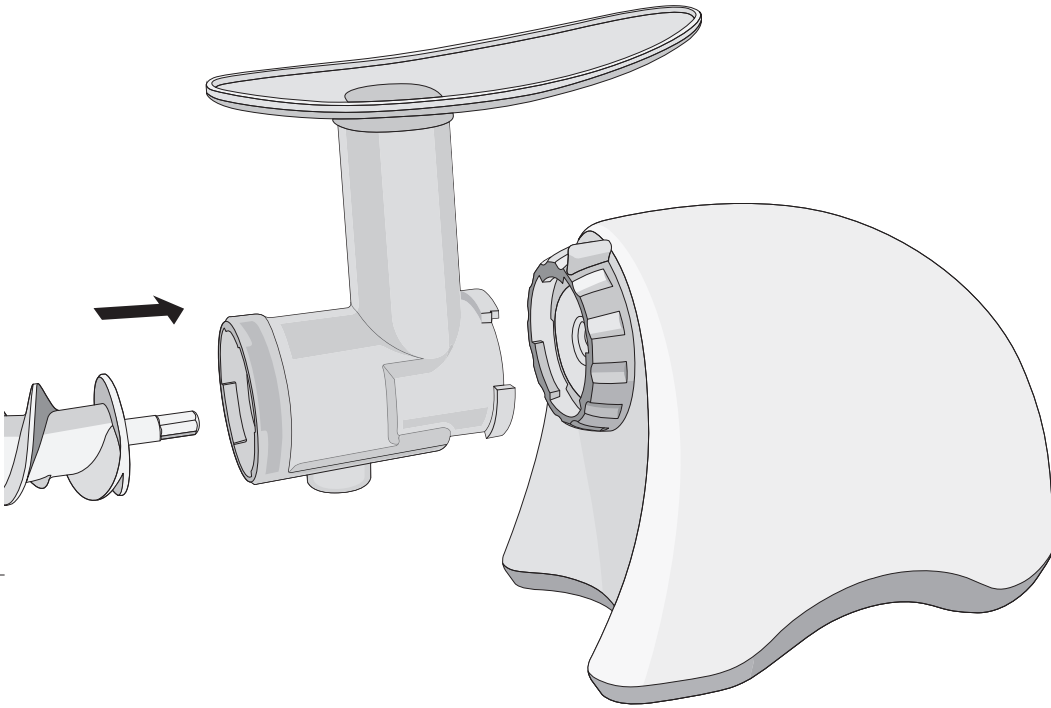

## ***Assembly 4***

Press the ON button. Place a few pieces of cut fruit or vegetables, one at a time into the guide. Use the food pusher to press the fruit or vegetables gently down the feeding tube. Leave the machine on as you feed in the fruits/vegetables.

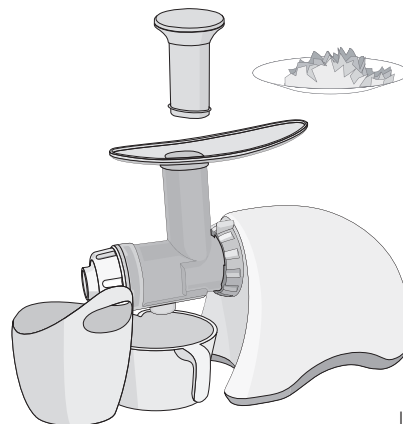

# Assembly Instructions

## Assembly 5

DO NOT place any metal objects into the hopper. If the drum set is clogged or the machine stops operating, press the reverse button 2 to 3 times which will clear the clogging. Press the on button again to resume normal operation.

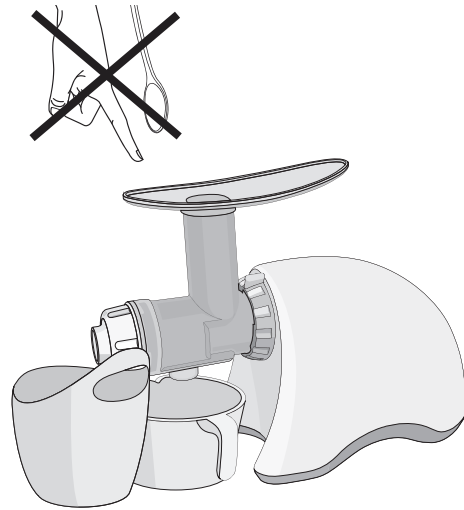

## Assembly 6

Switch the juicer OFF before changing accessories or touching any moving parts. Remove the drum set from the main body by turning the locking clip counter-clock wise. Pull the auger forward to disassemble it from the drum set. After juicing, wash all parts in warm soapy water. Do NOT place any of the juicer accessories in the dishwasher.

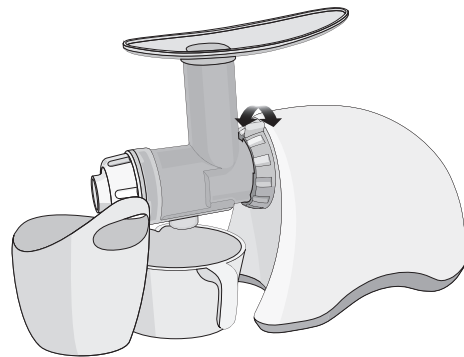

## Assembly 7

Do NOT run juicer for more than 30 minutes continuously at any one time.



# Making Pasta, U-dong, Noodle, Breadstick

## Assembly 1

Open and remove drum cap

Replace juicing strainer with processing strainer.

Place the desired nozzle into the front end of the processing strainer. Turn drum cap counter-clock-wise until it clips firmly into place.

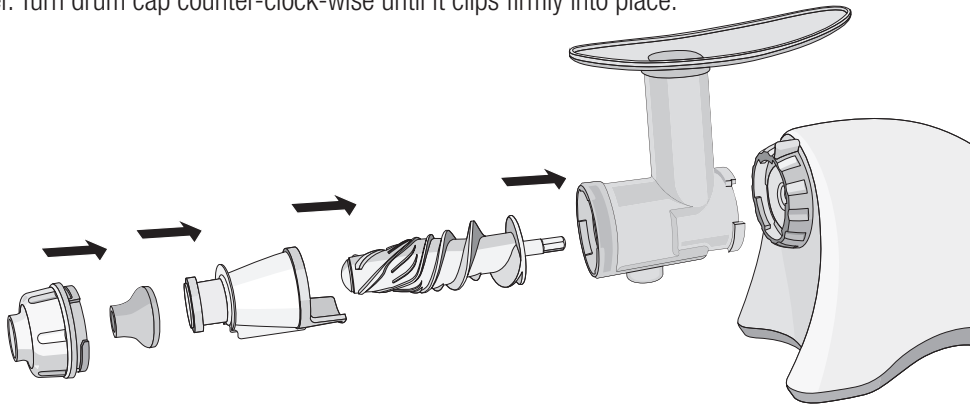

## Assembly 2

Sprinkle a small amount of wheat flour on the holding dish placed under the spout.

Press ON button.

Push pasta dough through the feeding tube without stopping.



## Assembly 3

Use scissors to cut the pasta to desired lengths. Cook according to recipe used.

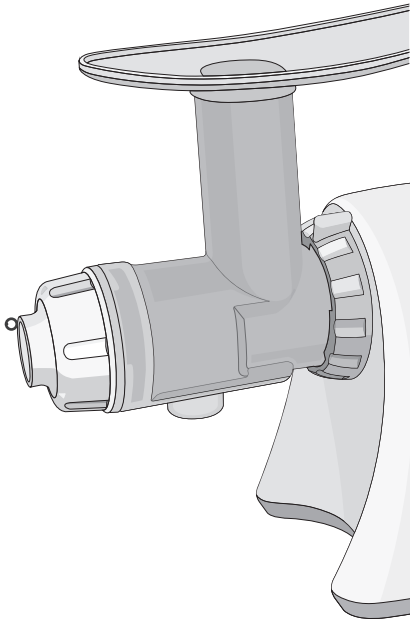

## Assembly 4

Disassemble unit and rinse all parts and accessories first in cold water. Then wash in warm soapy water in your sink – NOT in your dishwasher.

## Choosing the Right Strainer

Material	Strainer
Apples, Oranges, Pears, Grapes, Strawberries, Kiwi fruit, Tomatoes, Avocados, Aloe, and etc	Coarse juicing strainer
Pine tree leaves, kale, Radishes, Beet tops, spinach, carrots, yams, wheat grass and other leafy greens	Fine juicing strainer
Red/ green pepper, garlic, ginger, herbs, soaked rice and beans.	Processing strainer
Pasta, U-dong, Noodle Breadstick, Ice cream, Nut butter	Processing strainer

Sana  
JUICER® BY 